

**ISO9001:2015** 国际质量标准认证企业

## **SFD-600II 可燃/有毒气体探测器**

**SFD-600II flammable / toxic gas detector**

# 使用说明书



**SUOFUDA**

深圳市索福达电子有限公司  
深圳市索安达科技有限公司

## 公司简介 Company Profile

深圳市索福达电子有限公司的前身是深圳市索富光纤通信设备有限公司的工业安全产品设备部，2003 年公司经改制后成为独立法人，厂址位于深圳科技园中区。

我们从事可燃性/有毒性气体报警装置、各类气质分析仪表、粉尘检测仪表、工业计算机控制管理系统、大空间火灾监控系统的开发、生产和销售。我们拥有多项产品的自主知识产权，是国家认定的深圳市软件企业。

我们的可燃气体报警产品取得了公安部消防产品合格评定中心颁发的中国国家强制产品认证证书、国家防爆电气产品质量监督检验中心颁发的防爆电气设备防爆认证、广东省质量技术监督局颁发的计量器具制造许可证。

我们的产品广泛应用于核工业、石油化工、医药食品、燃气输配、建筑材料、冶金、船舶制造、海洋石油开采、化工仓储等行业，用户包括许多国有大型企业及著名跨国公司的在华企业（如中核集团、中石油长庆油田、中石化高桥石化、中国海洋石油销售有限公司、中国大唐、中国华电、中国华能、中国神华、富士康公司、华为技术有限公司、杜邦（中国）有限公司、住友金隆铜业有限公司、中集集团、比亚迪股份有限公司等）。

本公司开发生产、代理销售以下产品：

**SFD 系列可燃/有毒气体报警装置；**

**SFD 系列氢气、氧气、甲烷、硫化氢气体分析仪；**

**SFD 系列交流静电粉尘检测仪；**

**SFD 系列现场检测集中控制计算机管理系统；**

**代理 LA100 型火灾安全监控系统。**

我们是广东省安全生产监督管理局下属的广东省安全生产监督协会的理事单位会员、华润集团合格供应商、华电工程合格供应商、大唐集团合格供应商、中核集团合格供应商、中国海洋石油销售有限公司合格供应商、国家压力容器与管道安全工程技术研究中心协作单位。我们通过了新版的 ISO9001: 2015 质量管理体系认证，公司在内部管理、产品研发、生产制造、销售及售后服务等环节实现规范化、制度化和标准化操作。

我们十分注重加强与科研机构及高校的联系。先后与中国科技大学国家火灾科学重点实验室、中国科学院长春应用化学研究所建立院企合作关系，产品在自主研发的基础上兼容并蓄不断提升，具有很强的产品研发和产品售后服务保障能力。

我们已在全国各主要地区建立起完善的销售服务网络，有多家代理商及办事处，保证为广大用户提供可靠、快捷、安全地服务。

### Company Profile

Shenzhen suofuda Electronics Co., Ltd. is the predecessor of industrial safety products and equipment department of Shenzhen sofuo optical fiber communication equipment Co. Ltd., . The company was restructured as an independent legal person, which is located in Shenzhen science and Technology Parks in the Nanshan district in 2003.

We engaged in flammable / toxic gas alarm device, gas analysis instrument, dust detection instrument, industrial computer control system, large space fire monitoring system development, production and sales. We have a number of independent intellectual property rights of products, is recognized by the state of Shenzhen

software companies.

Our combustible gas alarm products got the product certification of the Ministry of public security fire products conformity assessment center issued a China national mandatory , the national explosion-proof electrical product quality supervision and Inspection Center issued explosion-proof explosion-proof electrical equipment , Guangdong Province Bureau of quality and Technical Supervision issued by the measurement equipment manufacturing license.

Products are widely used in nuclear industry, petroleum chemical industry, medicine and food, Gas transmission and distribution , building materials, metallurgy, shipbuilding, offshore oil and chemical storage industry, etc. Customers include many domestic large enterprises and well-known multinational companies in China (such as nuclear group, Changqing Oilfield PetroChina , Sinopec Gaoqiao Chinese petrochemical, offshore oil sales Co. , Chinese Datang, Huadian, Huaneng of China , Shenhua of China, Foxconn company, HUAWEI Technologies Co. , Ltd. , DuPont (China) Sumitomo jinlong copper Co. , CIMC, Byd Company Limited, etc.).

We are the member of the Guangdong Provincial Work Safety Supervision Bureau of the Guangdong production safety supervision Association, and qualified suppliers of Huarun power, Huadian Engineering , Datang Group, the nuclear group , China Offshore Oil Sales Co. Ltd. , national pressure vessel and pipeline safety engineering research center technical cooperation unit. We have passed the ISO9001:2008 quality management system certification. We operate standardization, institutionalization and standardization in the internal management, product development, manufacturing, sales and after-sales service and other aspects .

We are very focused on strengthening ties between the research institutions and universities. and establishing cooperative relations with the State Key Laboratory of fire science, University of Science and Technology of China, Changchun Institute of Applied Chemistry, Chinese Academy of Sciences Successively, products based on fully inclusive and equitable rising in the independent research, has a strong product development and customer service ability.

We have established a sound sales and service network in all major regions of the country, with a number of agents and offices to provide reliable, efficient and safe services to our customers.

地 址： 深圳市南山区高新区中区琼宇路 8 号金科工业大厦北座七层

联系电话： 0755-26734055 26738439 26738321 传 真： 0755-26734003

电子信箱：suofuda800@163.com

网 址：<http://www.suofuda.com>

## 注意事项

### Matters needing attention

1、SFD-600 II 可燃/有毒气体探测器以现场数字显示方式在线检测，并可使用高能磁棒在显示面板上设置或调试探测器，无需开盖。

SFD-600 II flammable / toxic gas detectors can detect gases and display on the real-time, and can use the magnet on the display panel to change or debugging, without opening the lid.

2、探测器必须使用独立的 24V 电源。不可使用 DCS 或 PLC、变频调速器等设备的 24V 电源，以免因电源的功率匹配或共地短路等问题而烧毁探测器或设备。

The detector must use an independent 24V power supply. Do not use DCS or PLC, frequency converter and other equipment of the 24V power supply, so as to avoid the power of matching error or short circuit and other issues and burning the detector or equipment.

3、安装时必须使用金属电缆套管，以增强设备的防水、防护、防雷性能。探测器进线口部分电缆与密封套必须密封，安装电缆套管的水平高度必须低于变送器进线口的位置，否则，水份会通过电缆渗入探测器内部，或通过未完全密封的进线口渗入，从而损坏探测器。

It must use the metal cable casing when the detector is installed, in order to enhance the equipment waterproof, protection, lightning protection performance. Part of the cable line port and detector into the sealing sleeve must be sealed, installation of cable casing level transmitter must be lower than the inlet position, otherwise, the water will penetrate through the internal cable detector, or through the line is not completely sealed into the mouth, thus damaging the detector.

4、SFD-600 II 可燃/有毒气体探测器投入使用后，维修时必须先断电，后开盖。

SFD-600 II flammable / toxic gas detector must be cut off, and then opening cover, when maintenance.

5、定期对探测器检验、标定气体，以确保其检测的灵敏度。

Regularly check and calibrate the detector to ensure the sensitivity of the detector.

6、如对本说明书提示的安全注意事项发生疑问，可咨询相关专业部门或联系本公司。如发现本说明书中未提及的安全信息，或有必须添加与纠正的内容，请直接与本公司联系，我们真诚地接受任何诚恳的批评与指正。

If you have any questions about the safety precautions suggested in this manual, you may contact the relevant professional department or contact the Company. If you have any safety information that is not mentioned in this manual or if you have to add and correct it, please contact us directly. We sincerely accept any sincere criticism and correction.

## 重 要 提 示

### IMPORTANT NOTICE

由于安装在易燃/易爆/有毒等高风险场所，必须了解清楚可能导致发生重大事故和人身伤亡的危险或安全隐患。清楚任何可能导致人身伤害或产品或财产损失的危险或安全隐患。由不正确安装、操作报警设备所造成的故障后果自负。

Since the detector install in a flammable / explosive / toxic and other dangerous place,it may lead to the accidents and the risk of casualties.it is at your peril when install or operate the devices incorrectly.

由于电子产品都会存在发生故障的可能；所以不等于安装了本装置，就能百分百保证安全。需明白本装置的功能只是起到提防万一的作用、为安全多增加一道防线。更多安全需要大家平时多加留意，小心生产，安全生产，加强安全意识，杜绝安全隐患。

It doesn't mean 100% safe when you use the devices because all the electronic device may break possibly.you should understand what you use the devices is in case of danger and increasing a line of defense.

## 目录 Catalog

一、产品概述和设计、制造、检定遵照的国家标准 National standards for the design and manufacture of the product and the compliance of the inspection.....	1
1.1 产品概述 product description.....	1
1.2 设计、制造、检定遵照的国家标准 National standards for design, manufacture and verification.....	1
1.3 产品特点 Product features.....	2
1.4 性能参数 performance parameter.....	2
1.5 产品选型、检测量程 Product selection, detection range.....	3
1.6 安装方法 Installation method.....	4
1.6.1 安装选点 Installation location.....	4
1.6.2 传输电缆选用 Transmission cable selection.....	6
1.6.3 外形尺寸、固定方式 Dimensions, fixed way.....	6
二、操作说明 Operating instructions.....	9
2.1 简易使用方法 How to use it.....	9
2.2 功能介绍 Function introduction.....	9
工作模式: Working mode.....	9
设置模式 Setting mode.....	9
报警点设置 Alarm set point.....	9
灵敏度调节 Sensitivity adjustment.....	10
零点校准 Zero calibration.....	10
4-20mA 标定菜单 4-20mA calibration menu.....	11
故障报告 Fault report.....	11
2.3 标定校准 Calibration calibration.....	11
三、输出标准电流信号介绍 Output standard current signal introduction.....	12
3.1 开关量使用方法 Using method of switch.....	12
3.2 4-20mA 信号使用方法 Using the method of 4-20mA signal.....	12
3.3 浓度显示对应电流(I+、GND)的输出值, 校验或标定参考表 The concentration value corresponds to the output current (I +, GND).....	13
3.4 通电注意事宜 Power notice.....	13
四、校准及标定方法 The methods of Calibration and calibration.....	13
五、仪器的维护 Maintenance of the instrument.....	14
5.1 传感器的寿命和校准周期 Sensor life and calibration cycle.....	14
5.2 传感器更换方法 Replacement method of sensor.....	14

## 一、产品概述和设计、制造、检定遵照的国家标准

National standards for the design and manufacture of the product and the compliance of the inspection

### 1.1 产品概述 product description

SFD-600 II 可燃/有毒气体探测器是固定安装在防爆场所的一次仪表，用于检测现场危险气体的泄露。整机为探测、显示、报警输出的一体化结构，采用隔爆式防爆型式。变送器与控制系统之间可根据现场需要采用开关量信号输出、4-20mA 工业标准信号输出等连接方式，可用三芯电缆连接消防控制中心、声光报警器、PLC 或 DCS 工业控制系统等。

SFD-600 II 可燃/有毒气体探测器可广泛应用于石油化工、燃气输配、建筑材料、核能及国防工业、冶金、船舶制造、海洋石油开采等行业。

SFD-600 II flammable / toxic gas detector is fixed in the explosion-proof place , which is used to detect the scene of dangerous gas leakage. The whole machine is an integrated structure of detection, display and alarm output. According to the needs of the scene, We use the switch signal output, 4-20mA industrial standard signal output and other connections between the transmitter and the control system. We can connect fire control center, sound and light alarm, PLC or DCS industrial control systems by using connect three-core cable. SFD-600 II flammable / toxic gas detectors can be widely used in petrochemical, gas transmission and distribution, building materials, nuclear and defense industry, metallurgy, shipbuilding, offshore oil extraction and other industries.

### 1.2 设计、制造、检定遵照的国家标准 National standards for design, manufacture and verification

《GB/T 191-2008 包装储运图示标志》

《GB/T 9969-2008 工业产品使用说明书 总则》

《GB15322.1-2003 可燃气体探测器第一部分：测量范围为 0-100%LEL 的点型可燃气体探测器》

《GB16838-2005 消防电子产品环境试验方法及严酷等级》

《JJG 693-2011 可燃气体报警器国家计量检定规程》

"GB/T 191-2008 packaging storage and transportation icon" "GB/T 9969-2008" instructions for use of industrial products.

"GB15322.1-2003 combustible gas detector part 1: a combustible gas detector with a measuring range of 0-100%LEL"

"GB16838-2005 fire electronic products environmental test methods and strict rating"

National metrological verification regulation of JJG 693-2011 combustible gas alarm

### 1.3 产品特点 Product features

**测量精度高。**测量精度及线性温度补偿技术国内同行业最高，接近国际先进水平；全量程测量精度达到 $\pm 1\%FS$ ；通过内部参数设置，可支持多种不同检测类型的进口气体传感器。

High precision measurement. Measurement accuracy and linear temperature compensation technology is the highest in the same industry, which is close to the international advanced level; all range measurement accuracy of is near to  $\pm 1\% FS$ ; we can support a variety of gas sensors, through setting the internal parameters .

**显示直观：**4 位数码管显示，抗干扰，抗低温、耐高温。

Visual display: 4 digital tube display, anti-interference, low temperature, high temperature resistance.

**防爆设计、安全调试。**用于工业级别的 1、2 区危险场所。使用现场最安全可靠的高斯磁棒进行参数调试，避免了开盖、机体按键及遥控调试所带来的可靠性低、防护防爆性差等缺点。

Explosion - proof design, safety debugging. The device is install on industrial-grade hazardous locations, which is using the safest and reliable Gaussian magnetic bar for parameter debugging, to avoid the open cover, and low reliability, poor protection and other shortcomings by using the body buttons and remote control.

**方便灵活、多功能、多种信号输出。**可输出 4-20mA 标准电流信号、报警点直流驱动信号（驱动容量 DC24V/1A）。

Convenient and flexible, multi-function, a variety of signal output. It Can output 4-20mA standard current signal, alarm signal (drive capacity DC24V / 1A).

**灵敏度线性智能补偿功能。**由于大多数气体传感器的灵敏度线性会随时间的增加而下降（传感器灵敏度每月下降 1-2%），我们首创的只须磁棒调试的传感器智能线性补偿技术，大大提高了气体探测的精确性与安全性。

Intelligent sensitivity linear compensation. As the sensitivity of most gas sensors decreases linearly with the time fles (sensor sensitivity decreases by 1-2% per month), our intelligent linear compensation technology greatly improves the accuracy and safety of gas detection.

### 1.4 性能参数 performance parameter

**检测传感器：**可选用催化燃烧式、电化学式、固态半导体式、红外线式或光电离子式传感器。

Detection sensor: catalytic combustion sensor, electrochemical sensor, solid-state semiconductor sensor, infrared sensor, photoelectric ion sensor.

**检测气体：**一般可燃气体，氨气，苯及芳香类气体，氢气，氯气，一氧化碳，硫化氢，二氧化碳，氧气、甲苯二异氰酸酯（简称 TDI）等。



Detection of gas: combustible gas, ammonia, benzene and aromatic gas, hydrogen, chlorine, hydrogen sulfide, carbon monoxide, carbon dioxide, oxygen, toluene diisocyanate (TDI) etc..

测量范围: 0-100%LEL 0-9999ppm; 0-100%VOL ; 0-0.05mg/m<sup>3</sup> (TDI)

精 度: ±5%FS、±0.01%FS (TDI)

报警设定: 报警点可调

响应时间: 15S

恢复时间: 30S

防爆方式: 隔爆型

防爆标志: Exd II CT6 Gb

防护级别: IP66

防爆连接: G3/4 管螺纹

输出信号: 4~20mA 标准信号输出; 两路直流 24V 开关量信号输出。

温度范围: -40℃至 +70℃ (如使用耐高温可燃气体传感器, 其温度适用范围为-40℃至 +250℃)。

相对湿度: <95%.

电 源: DC24V(DC15V~DC28V)

功 耗: <5W/路

重 量: 约为 3kg/路

Measuring range: 0-100%LEL 0-1000ppm; 0-100%VOL; 0-0.05mg/m<sup>3</sup> (TDI)

Accuracy: + 5%FS, + 0.01%FS (TDI)

Alarm settings: alarm points adjustable

Response time: 15S

Recovery time: 30S

Explosion proof: Flameproof

Explosion proof mark: Exd II CT6 Gb

Protection level: IP66

Explosion proof connection: G3/4 pipe thread

Output signal: 4~20mA standard signal output; two way DC 24V switch signal output.

Temperature range: -40 degrees to +70 degrees (such as the use of high-temperature combustible gas sensor, the temperature range of -40 DEG C to 250 C).

Relative humidity: <95%

Power supply: DC24V (DC15V ~ DC28V)

Power consumption: <5W/ Road

Weight: about 3kg/ Road

## 1.5 产品选型、检测量程 Product selection, detection range

SFD-600 II 可燃/有毒气体探测器的命名方法如下:

- “SFD”代表“索福达”。
- “600”代表检测变送器。
- 右数第一个“X”代表所检测的气体对象; 例: “T”、“F”、“N”、“H”、“C”、

“SO”、“HF”、“CL”分别代表一般可燃气体、苯及芳香类化合物气体、氨气、氢气、一氧化碳气体、二氧化硫、氟化氢、氯气（尚未列举的气体种类，以其化学分子式为代表）。

d、右数第二个“X”代表气体传感器的类型，“C”代表催化燃烧式，“D”代表电化学式，“G”代表固态半导体式，“I”代表红外线式，“P”代表光电离子式，“M”代表金属氧化物式。

SFD-600 II combustible / toxic gas detectors are named as follows:

A, "SFD" stands for "Fuda cable".

B, "600" represents the detection transmitter.

C, The first "X" on behalf of the gas detection; example: "T", "F", "N", "H", "C", "SO", "HF" and "CL" represent the general combustible gas, benzene and aromatic compounds gas, ammonia, hydrogen, carbon monoxide, sulfur dioxide, hydrogen fluoride, chlorine gas (gas species, not yet listed with its chemical formula as the representative).

D, Second types of "X" on behalf of the gas sensor, "C" represents the catalytic combustion type, "D" represents the electrochemical type, "G" represents a solid semiconductor type, "I" represents the infrared type, "P" stands for "M" type photoelectric ion, representative of metal oxide type.

SFD-600 II TC	一般可燃性气体	Combustible gas	0-100%LEL
SFD-600 II HD	氢气	hydrogen	0-100%LEL
SFD-600 II FD	苯及芳香类化合物	Benzene compounds	0-100PPM
SFD-600 II SD	硫化氢	Hydrogen sulfide	0-10PPM、50PPM、100PPM
SFD-600 II ND	氨气	ammonia	0-500PPM、0-100PPM
SFD-600 II CD	一氧化碳	Carbon monoxide	0-500PPM、1000PPM、5000PPM
SFD-600 II CO2I	二氧化碳	Carbon dioxide	0-100%VOL
SFD-600 II CLD	氯气	Chlorine	0-10PPM
SFD-600 II SO2D	二氧化硫	sulfur dioxide	0-500PPM
SFD-600 II F2D	氟气	Fluorine gas	0-1PPM、2PPM
SFD-600 II HFD	氟化氢	Hydrogen fluoride	0-10PPM
SFD-600 II O2D	氧气	oxygen	0-25%VOL
SFD-600 II HCL2D	氯化氢	hydrogen chloride	0-10PPM、20PPM、30PPM
SFD-600 II HCND	氢氰酸	Hydrocyanic acid	0-10PPM、20PPM、50PPM、100PPM
SFD-600 II COCL2D	光气	carbonyl chloride	0-1PPM
SFD-600 II SIH4D	硅烷	silane	0-50PPM
SFD-600 II TDIP	甲苯二异氰酸酯	toluene diisocyanate	0-0.05mg/m <sup>3</sup>

## 1.6 安装方法 Installation method

### 1.6.1 安装选点 Installation location

A. 不要安装在热源或振动源上。

A. do not install in high temperature or vibration place.

**B**、在建筑物内的压缩机、泵、阀、反应贮罐和其他容易产生可燃性气体泄露的高压气体设备的周围，按不大于 10 米的间隔,应配置一台可燃气体探测器。

in the building of compressor,the pump, valve, reaction tank and other equipment that is prone to flammable gas leaks, should be equipped with a combustible gas detector by not more than 10 meters .

**C**、在建筑物外的上述设备的周围，应按不大于 20 米的间隔；这些设备周围容易滞留可燃气体的地方，应配置一个以上。

At the end of the above-mentioned equipment outside the building, at least one detector shall be arranged at intervals not to exceed 20 meters.

**D**、在有加热炉等火源的生产设施周围，应按不大于 20 米的间隔配置；这些设备周围容易滞留可燃气体的地方，应配置一个以上。

In the presence of a heating furnace, such as a heating furnace, at least one detector shall be installed at intervals not to exceed 20 meters.

**E**、设备上充装可燃气体、液体的连接口周围，应配置一个以上。

Filling combustible gas, liquid equipment around the mouth, should be configured more than one.

**F**、被测气体比空气重的情况下，安装高度应接近地面，同时不要安装在热源或振动源上。  
When the measured gas is heavier than air, the installation height should be close to the ground and not on a heat source or vibration source.

**G**、被测气体比空气轻的情况下，安装高度应高于可能的泄露点。

When the measured gas is lighter than air, the installation height should be higher than the possible leak.

1.6.2 传输电缆选用 Transmission cable selection

A、传输距离如下表：The transmission distance is as follows:

表 1、 电缆传输距离表  
Cable transmission distance table

芯线截线面积 Core line area	0.75mm <sup>2</sup>	1.00mm <sup>2</sup>	1.50mm <sup>2</sup>	2.50mm <sup>2</sup>	4.00mm <sup>2</sup>
铜芯千米电阻 Copper core resistance	17.50	13.13	8.75	5.25	3.28
最远传输距离 Farthest transmission distance	1140m	1520m	2280m	3800m	6090m

在防爆场所，电缆芯线必须采用符合国家标准的铜线，电缆单芯截面积应大于 1mm<sup>2</sup>；如需接头，必须采用防爆接线盒；非铠装电缆必须采用穿钢管防护敷设；钢管与变送器进线口（G3/4”）可直接套线连接，或加防爆连接软管。

In the explosion-proof places, the cable core must be in line with national standards of copper, cable single-core cross-sectional area should be greater than 1 square millimeter. For connection, must use explosion-proof junction box; wiring must be used to wear pipe protection laying; steel pipe and transmitter inlet can be directly connected to the line, or add explosion-proof connection hose.

1.6.3 外形尺寸、固定方式 Dimensions, fixed way

A、变送器安装点距离地面的高度，不要低于 0.3 米，这是为避免地面溅水和油尘污染。

The height of the transmitter installed from the ground, not less than 0.3 meters, which is to avoid splashing and dust pollution.

B、安装在支架上，传感器盖向下，变送器可用 φ 25~35mm 桩管固定于地面或用膨胀螺钉固定于墙上。

Installed in the bracket, the sensor direction is down, the transmitter can be fixed with φ 25 ~ 35mm pile on the ground or using the expansion screw fixed to the wall.

外型尺寸图: Dimension drawing:

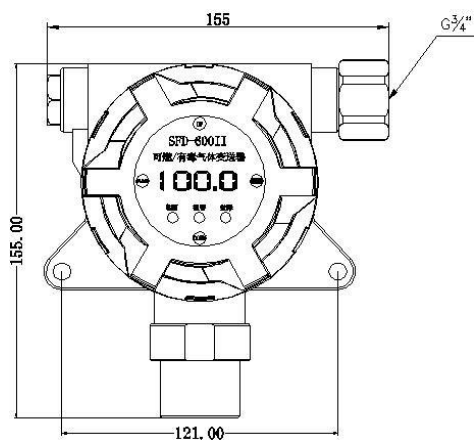

(图 1) 探测器正面图  
(Figure 1) detector front view

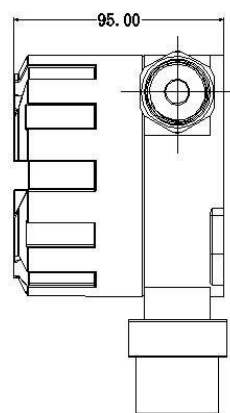

(图 2) 探测器侧面图  
(Figure 2) detector side view

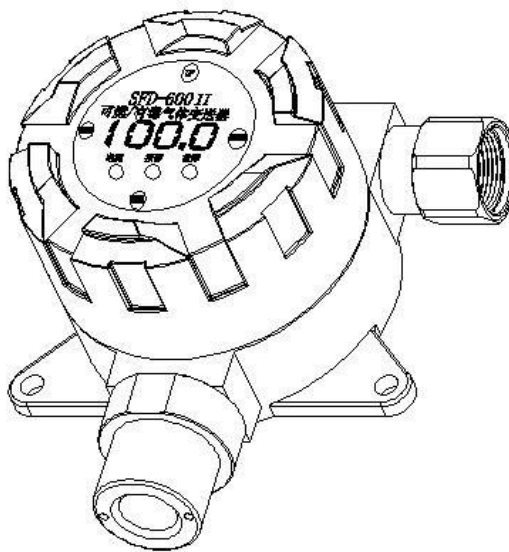

(图 3) 探测器立体图  
(Figure 3) detector three-dimensional map

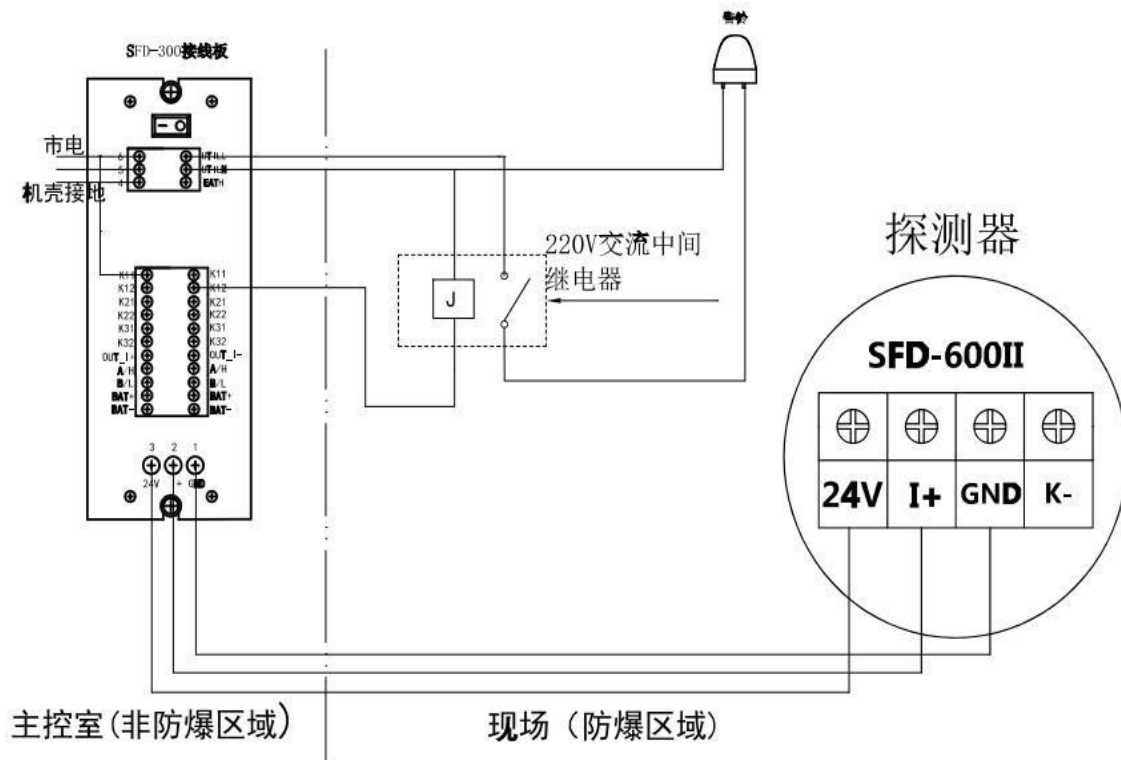

(图 4) 探测器接线图  
(Figure 4) Detector wiring diagram

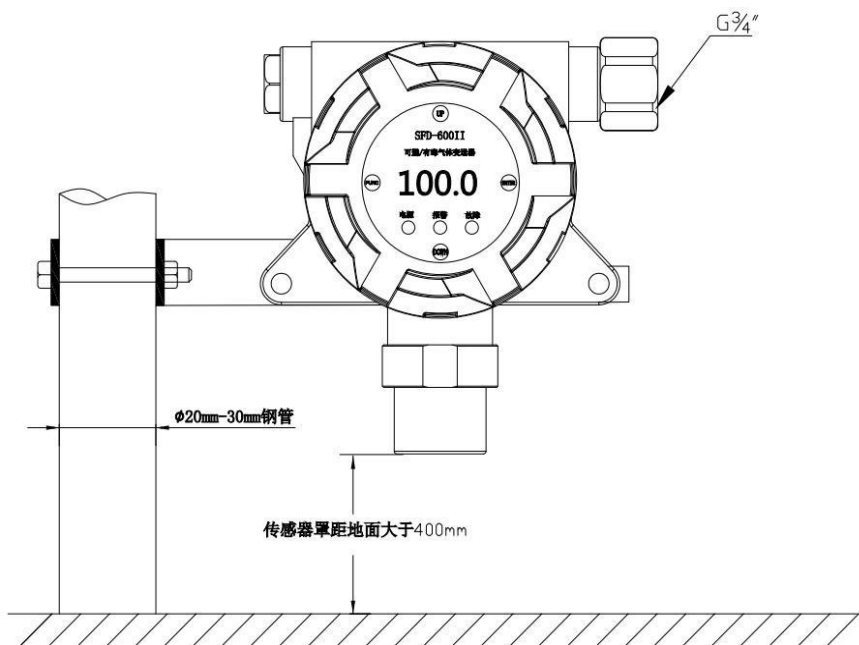

(图 5) 探测器安装示意图  
(Figure 5) detector installation diagram

## 二、操作说明 Operating instructions

### 2.1 简易使用方法 How to use it

A、连接上 24V 直流电源，探测器将进行 60 秒钟的自检与预热，然后进入浓度显示界面。

B、用标准气体，探测器的显示值值会对应气体的浓度变化；当浓度大于设定的报警值时，24V/A 开关量输出信号，4-20mA 输出值与浓度值对应。

When the device is connected to the 24V DC power supply, it will be 60 seconds of self inspection and pre heating, and then enter the detection interface.

Through the standard gas, the display value of the detector will correspond to the change of the concentration of the gas. When the gas concentration is greater than the set alarm value, the 24V/A switch will output the signal, and the 4-20mA output value will correspond to the concentration value.

### 2.2 功能介绍 Function introduction

显示模式 display mode	操作方法 Operation method
<b>00.0L</b>	<p style="text-align: center;"><b>工作模式: Working mode</b></p> <p>00.0: 表示当前测量的气体浓度。L: 表示测量气体的浓度单位%LEL。 00.0: means the current gas concentration. L: means to measure the gas concentration unit (%LEL).</p>
<b>P-A1</b>  <b>A-25</b>	<p style="text-align: center;"><b>设置模式 Setting mode</b></p> <p>用磁棒点按“FUNC”键约 3 秒，则进入设置模式，若无任何操作，90 秒后自动退出。</p> <p style="text-align: center;"><b>报警点设置 Alarm set point</b></p> <p>A-XX:A 表示报警点(alarm), xx 表示报警值，达到该值即报警。 进入报警点设置模式后，点按“ENTER”，则进入该界面，出厂默认报警值为“25”。此时用磁棒短按“UP”或“DOWN”，即可更改报警点。报警数值在 0~99 之间任意可调（根据客户对现场的不同要求），保存退出用“ENTER”。</p> <p>Click the "FUNC" button for about 3 seconds by magnetic bar, then enter the setting mode, it will automatically exit after 90 seconds without any operation.</p> <p>A-XX:A indicates alarm point (alarm), XX indicates alarm value which will alarm if the detection value exceeds the value. After entering the alarm-point setting mode, click "ENTER", then enter the</p>

	<p>interface, the default alarm value is 25. When the bar click "UP" or "DOWN", you can change the alarm point. The alarm value can be change between 0 ~ 99 (according to the different requirements of customers), click "ENTER" will save and exit.</p>
<p><b>2E-0</b> <b>L02.3</b></p>	<p><b>零点校准 Zero calibration</b> 直接延续操作进入“零点校准”菜单后，屏幕显示“ZERO”，如需校准零点，则轻触“ENTER”键，显示“L”开头的“XX”非零点数值，用磁棒点按“DOWN”键使显示值为零即可，点按“ENTER”确认并进入下一级菜单。 Continuation of the above operation, enter the "zero calibration" menu, the screen will displays "ZERO", if you want to calibrate the zero, then click "ENTER" button , and then display "L" at the beginning of the "XX" non-zero value, click "DOWN" To make the value zero, press "ENTER" to confirm and then enter the next level menu.</p>
<p><b>SPAN</b> <b>H60.1</b></p>	<p><b>灵敏度调节 Sensitivity adjustment</b> SPAN: 灵敏度调节 按上述步骤，若出现“SPAN”字样，点按“ENTER”键，进入“H”开头的“XX”现有气体浓度值，送入标准气（比如送 30%LEL）后，如显示值低于或高于标准气值，用磁棒点按“UP”“DOWN”键使显示值与标准气浓度值相符即可。点按“FUNC”确认并进入下一级菜单。 SPAN: sensitivity adjustment According to the above steps, if there is "SPAN", then click "ENTER" button to enter the calibration interface. First pass the standard into gas sensor (such as 30%LEL) , if the display value is lower than or higher than the standard gas value, click the "UP" "DOWN" key to adjust to make it consistent with the standard gas. Click "FUNC" to confirm and enter the next menu.</p>



<p>P-20</p> <p>P-04</p>	<p><b>4-20mA 标定菜单 4-20mA calibration menu</b></p> <p>点按“FUNC”选择“4-20mA 标定”，屏幕显示“P-04”或者“P-20”时，用磁棒短触“FUNC”键，用磁棒短按“UP”“DOWN”键，即可微调其相应值，在输出端子 I+、GND 上连接电流表，可以测量对应的 4mA 和 20mA 输出电流，用磁棒短按“FUNC”退出。</p> <p>Press "FUNC" to select "4-20mA calibration". When "P-04" or "P-20" is displayed on the screen, press the "FUNC" key by using the magnetic bar, then press "UP""DOWN", you can adjust the value. Then connect the ammeter in the terminal of "I+" "GND", you can measure the current whether is 4mA and 20mA, then press "FUNC" to exit the menu.</p>
<p>Err1</p>	<p><b>故障报告 Fault report</b></p> <p>如果显示该界面，则说明有故障，需返厂维修。</p> <p>Err1:传感器故障。</p> <p>If the detector shows it on the screen, it is faulty and needs to be repaired.</p> <p>Err1: sensor fault.</p>

## 2.3 标定校准 Calibration calibration

探测器采用两点校准法进行标定，具体如下所述：

在标定过程中，点按功能键进入“零点校准（‘ZERO’）”和“量程校准（‘SPAN’）”界面，然后点击右键“ENTER”进入“零点校准”和“量程校准”。校准时分别将纯净空气（零点气体）和标定样本气体（通常为甲烷）通过气体标定罩导入“检测气体进气口”（以下简称“检测口”，校准时，通过按钮“UP”“DOWN”调节使示数为标气的值，并通过“Enter”，退出保存。

注：建议标准气体的浓度为满量程的 **50-75%**，送入气体的流量控制在 500mL/min。

The detector is calibrated using a two-point calibration method, as follows:

In the calibration process, click the function key to enter the "zero calibration ('ZERO') and "range calibration ('SPAN') interface, and then right click "ENTER" to enter "zero calibration" and "range calibration". When the equipment is calibrated, pure air (zero gas) and calibration sample gas (usually methane) are passed into the "detector" through the gas calibration hood. You can click the button "UP" "DOWN" to adjust the number of indicators for the standard value, and click "Enter" to exit and save.

Note: It is recommended that the standard gas concentration be 50-75% of full scale and the flow rate of the feed gas is controlled at 500 mL / min.

### 三、输出标准电流信号介绍 **Output standard current signal introduction**

#### 3.1 开关量使用方法 **Using method of switch**

直接带 24V/1A 以内的直流负载，例如报警灯。24V 接直流负载的正极，K - 接直流负载的负极，报警时可驱动该负载。

Direct drive 24V/1A DC load, such as alarm lights. The 24V is connected with the positive pole of the DC load, and the K- is connected with negative electrode of the DC load.

#### 3.2 4-20mA 信号使用方法 **Using the method of 4-20mA signal**

4-20mA 是国际通用的工业标准信号，是连接仪表、变送设备、控制设备、计算机采样设备的一种标准。可远距离传输模拟信号，不会因有线路消耗存在压降而产生大的信号误差。

4-20mA is an international industrial standard signal, it is a standard for connecting instrument, transmission equipment, control equipment and computer sampling equipment. It can transmit analog signals over a long distance, and it will not produce a large signal error due to the pressure drop.

使用 4-20mA 信号时，I+和 GND 两个端子构成 4-20mA 信号回路；探测器必须使用独立电源 24V，不可使用 DCS 或 PLC、变频调速器等设备的 24V 电源，以免因电源的功率匹配或共地短路等问题而烧毁探测器或设备。

When using the 4-20mA signal, I+ and GND constitute the 4-20mA signal loop; The detector must use an independent 24V power supply. Do not use DCS or PLC, frequency converter and other equipment of the 24V power supply, so as to avoid the power of matching error or short circuit and other issues and burning the detector or equipment.

接线方法：采用独立电源三线制接线方式

connection: using three independent power supply connecting wire connection mode

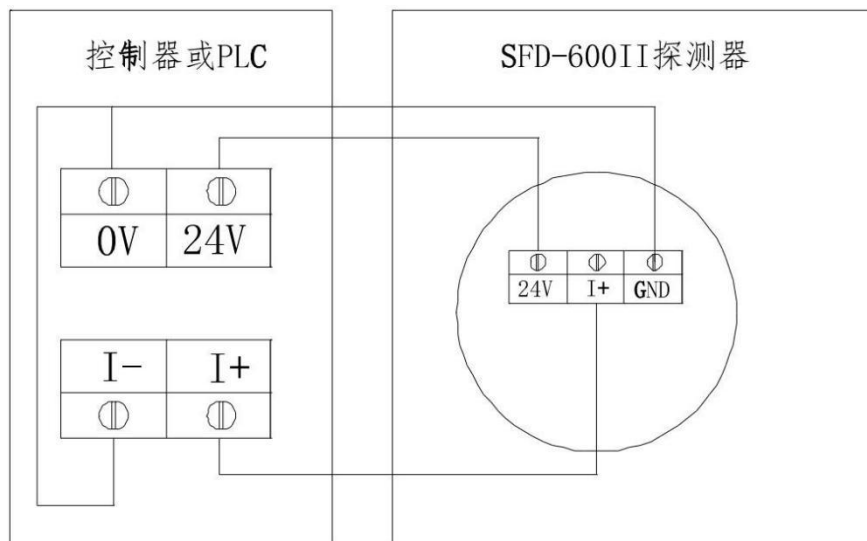

(图 6) 探测器接入报警器或 PLC 系统接线图  
(Figure 6) detector connect with the alarm or PLC system

### 3.3 浓度显示对应电流(I+、GND)的输出值, 校验或标定参考表

The concentration value corresponds to the output current (I +, GND)

浓度%LEL	电流 mA	浓度%LEL	电流 mA
0	4	50	12
10	5.6	60	13.6
20	7.2	70	15.2
25	8.0	80	16.8
30	8.8	90	18.4
40	10.4	100	20

### 3.4 通电注意事宜 Power notice

- (1) 通电前请确认 24V 电源的正负极不可接反。
- (2) 单独使用探测器时, 探测器推存使用独立电源 24V。
- (3) 通电前请确认接线方法是否正确。

(1) make sure that the positive and negative poles of the 24V power supply can not be connected before the power is turned on.

(2) when the detector is used alone, the detector is driven by an independent power supply 24V.

- (3) please confirm whether the connection method is correct before power up.

## 四、校准及标定方法 The methods of Calibration and calibration

产品在出厂时已经标定好, 一般在半年内不必再标定。如果已经连续使用超过 6 个月, 则数值会有少许偏差, 可使用标准样气进行标定。

Products in the factory has been calibrated, generally do not have to re calibration within six months. If it has been used for more than 6 months, the value will be a little deviation, it can be used to calibrate the standard sample gas.

标定方法如下: 屏幕显示默认界面 0.0 时, 用磁棒触“FUNC”键约 5 秒, 然后放开, 进入菜单参数设置, 并轻触两下“FUNC”键, 屏幕显示“SPAN”, 轻触“ENTER”键(右键), 进入“H”开头的“XX”现有气体浓度值, 送入标准气(比如送 30%LEL)后, 如显示值低于或高于标准气值, 用磁棒点按“up”“down”键调节使显示值与标准气浓度值相符即可。点按“FUNC”确认保存并进入下一级菜单。

The calibration method is as follows: when the screen displays is working normal, then use the Magnetic bar to click "FUNC" button for about 5 seconds, then release, enter the menu settings, and click the twice the "FUNC" button, the screen shows "SPAN", click "ENTER" button, the "H" is at the beginning "XX is the gas concentration, put the gas into the device(such as 30%LEL), when the display value is lower or higher than the standard value, click "up" to "down" button to adjust the concentration by using the Magnetic bar. Click "FUNC" to save and enter the next menu.

请不要带电打开探测器的外壳, 送标准样气到探头, 可以使用高级参数菜单中的 SPAN (灵敏度调整) 和 SEN (修正值调整) 进行在线调整。调整公式如下:

Forbidden to open the detector shell when power on. The standard sample gas is sent to the sensor, which can be adjusted online using the SPAN (sensitivity adjustment) and SEN (correction

value adjustment) in the advanced parameter menu. The formula is as follows:

$$\text{标定显示值} = \text{原来浓度显示} * \text{SEN}$$

$$\text{Calibration display-value} = \text{original density display} * \text{SEN}$$

## 五、仪器的维护 Maintenance of the instrument

### 5.1 传感器的寿命和校准周期 Sensor life and calibration cycle

探测器在正常的使用中，催化燃烧传感器的有效使用寿命小于 4 年。电化学传感器小于 2 年。在有效使用寿命期内，每 6 个月要定期对传感器进行一次标定检查，以保证气体监测准确有效。超过有效使用期的和有故障的传感器必须及时进行更换。

When the detector is in normal use, the catalytic life of the catalytic combustion sensor is less than 4 years while the electrochemical sensor is less than 2 years.

The sensor should be periodically calibrated every 6 months to ensure accurate and effective. The faulty sensors and the out of validity sensors must be replaced in time.

### 5.2 传感器更换方法 Replacement method of sensor

断开探测器电源，逆时针旋开传感器，取出旧的传感器；将新的传感器安装到位，顺时针旋紧传感器，传感器更换完成，接通电源进入正常工作模式。

Turn off the power, counterclockwise unscrew the sensor, take out the old sensor, install the sensor clockwise, sensors have been replaced, turn on the power and enter the normal mode of operation.

### 可燃气体和有毒气体的性质

物质名称	分子式 (化学式)	燃烧(爆炸) 范围 (Vol.%)	爆炸 等级	燃烧度	引火度 (°C)	容许浓度 (ppm)	气体比重 (空气=1)
乙炔	HC=CH	2.5~81.0 %	3	G2	(气体)		0.90
乙醛	CH <sub>3</sub> CHO	4.0~60.0	1	" 4	-3.9	100	1.52
乙烷	C <sub>2</sub> H <sub>6</sub>	3.0~12.4			-183.2		1.0
乙胺	C <sub>2</sub> H <sub>5</sub> NH <sub>2</sub>	3.5~14.0				10	1.6
苯乙烷	C <sub>6</sub> H <sub>5</sub> C <sub>2</sub> H <sub>5</sub>	1.0~6.7			15	100	0.9
乙烯	CH <sub>2</sub> =CH <sub>2</sub>	2.7~36.0	2	" 2	(气体)		0.97
氯乙烷	C <sub>2</sub> H <sub>5</sub> CL	3.8~15.4			-50	1000	0.9
氯乙烯	CH <sub>2</sub> =CHCL	3.6~33.0	1	" 1	-78	2.5	2.15
氧化丙烯	CH <sub>3</sub> CHCH <sub>2</sub> O	2.1~21.5			-37	100	2.0
环丙烷	C <sub>3</sub> H <sub>6</sub>	2.4~10.4					1.5
二甲胺	(CH <sub>3</sub> ) <sub>2</sub> NH	2.8~14.4				10	
氢	H <sub>2</sub>	4.0~75.0	3	" 1	(气体)		0.07
丁二烯	CH <sub>2</sub> =CHCH=CH <sub>2</sub>	2.0~12.0	2	" 2	-85	1000	1.87
丁烷	CH <sub>3</sub> (CH <sub>2</sub> ) <sub>2</sub> CH <sub>3</sub>	1.8~8.4	1	" 2	(气体)		2.01
丁烯	C <sub>4</sub> H <sub>8</sub>	1.6~9.7	1	" 2	(气体)		1.93
丙烷	CH <sub>3</sub> CH <sub>2</sub> CH <sub>3</sub>	2.1~9.5	1	" 1	(气体)		1.56
丙烯	CH <sub>3</sub> CH=CH <sub>2</sub>	2.4~11.0	1	" 1	(气体)		1.50
甲烷	CH <sub>4</sub>	5.0~15.0	1	" 1	(气体)		0.55
甲基醚	CH <sub>3</sub> OCH <sub>3</sub>	3.4~27.0					
戊烷	C <sub>5</sub> H <sub>12</sub>	1.5~7.8	1	" 3	<-40	1000	2.48
正乙烷	C <sub>6</sub> H <sub>14</sub>	1.2~7.5	1	" 3	-21.7	500	2.98
丙酮	CH <sub>3</sub> COCH <sub>3</sub>	2.1~13.0	1	" 1	-19	200	2.48
丁酮	CH <sub>3</sub> COC <sub>2</sub> H <sub>5</sub>	1.8~10.0	1	" 1	-9	200	2.48
醋酸乙酯	CH <sub>3</sub> COOC <sub>2</sub> H <sub>5</sub>	2.1~11.5	1	" 1	-4.4	400	3.04
醋酸丁酯	CH <sub>3</sub> COOC <sub>4</sub> H <sub>9</sub>	1.7~7.6	1	" 2	22	150	4.01
城市煤气		5.0~	2	" 1	(气体)		0.2~0.4
液化石油气		2.0~12.0	1	" 1	(气体)	1000	1.5~2.0
汽油		1.4~7.6	1	" 3	-42.8	500	3~4
煤油		0.8~	1	" 3	35~50		5~
丙烯腈	CH <sub>2</sub> =CHCN	3.0~17.0	1	" 1	-1	20	1.83
丙烯醛	CH <sub>2</sub> =CHCHO	2.8~31.0			-26	0.1	1.9
氨	NH <sub>3</sub>	15.0~28.0	1	" 1	(气体)	25	0.6
一氧化碳	CO	12.5~74.0	1	" 1	(气体)	50	0.97
氯甲烷	CH <sub>3</sub> CL	7.0~17.4				100	
氧化乙烯	(CH <sub>2</sub> ) <sub>2</sub> O	3.6~100..	1	" 2	<-17.8	1	1.52
腈化氢	HCN	5.6~40.0	1	" 1	-17.8	10	0.93
三甲胺	(CH <sub>3</sub> ) <sub>3</sub> N	2.0~12.0				10	2.0
二硫化碳	CS <sub>2</sub>	1.3~50.0				20	2.6
溴化甲基	CH <sub>3</sub> Br	10.0~15.0	1	" 1	事实上不燃烧	5	3.3
苯	C <sub>6</sub> H <sub>6</sub>	1.3~7.1	1	" 1	-11	10	2.8
甲苯	C <sub>6</sub> H <sub>5</sub> CH <sub>3</sub>	1.4~6.7	1	" 1	-4	100	2.48
邻二甲苯	C <sub>6</sub> H <sub>4</sub> (CH <sub>3</sub> ) <sub>2</sub>	1.0~6.0	1	" 1	-32	100	2.48
甲醇	CH <sub>3</sub> OH	7.3~36.0	1	" 1	11	200	3.04
乙醇	C <sub>2</sub> H <sub>5</sub> OH	3.3~19.0	1	" 2	13	1000	4.01
单甲胺	CH <sub>3</sub> NH <sub>2</sub>	4.9~20.7				10	1.1
硫化氢	H <sub>2</sub> S	4.0~44.0	1	" 1	(气体)	10	1.19
二氧化硫	SO <sub>2</sub>	~				2	2.3
氯	CL <sub>2</sub>	~			不燃烧	1	2.5
二乙基胺	(C <sub>2</sub> H <sub>5</sub> ) <sub>2</sub> NH	1.8~10			-23	10	2.5
氟	F <sub>2</sub>	和氧化物 反应起火				1	1.7
碳酰氯	COCL <sub>2</sub>				不燃烧	0.1	3.2
氯丁二烯	C <sub>4</sub> C <sub>5</sub> CL	4.0~20.0			-20	10	



[www.suofuda.com](http://www.suofuda.com)

 **SUOFUDA**

深圳市索福达电子有限公司  
深圳市索安达科技有限公司

地址：深圳市南山区高新区中区琼宇路8号金科工业大厦北座七层 邮编：518057

电话：0755-2673 4055 2673 8439 2673 8321

免费服务电话：400 688 6872

传真：0755-2673 4003

邮箱：[suofuda800@163.com](mailto:suofuda800@163.com)

网址：[www.suofuda.com](http://www.suofuda.com)



粤制 00000719